

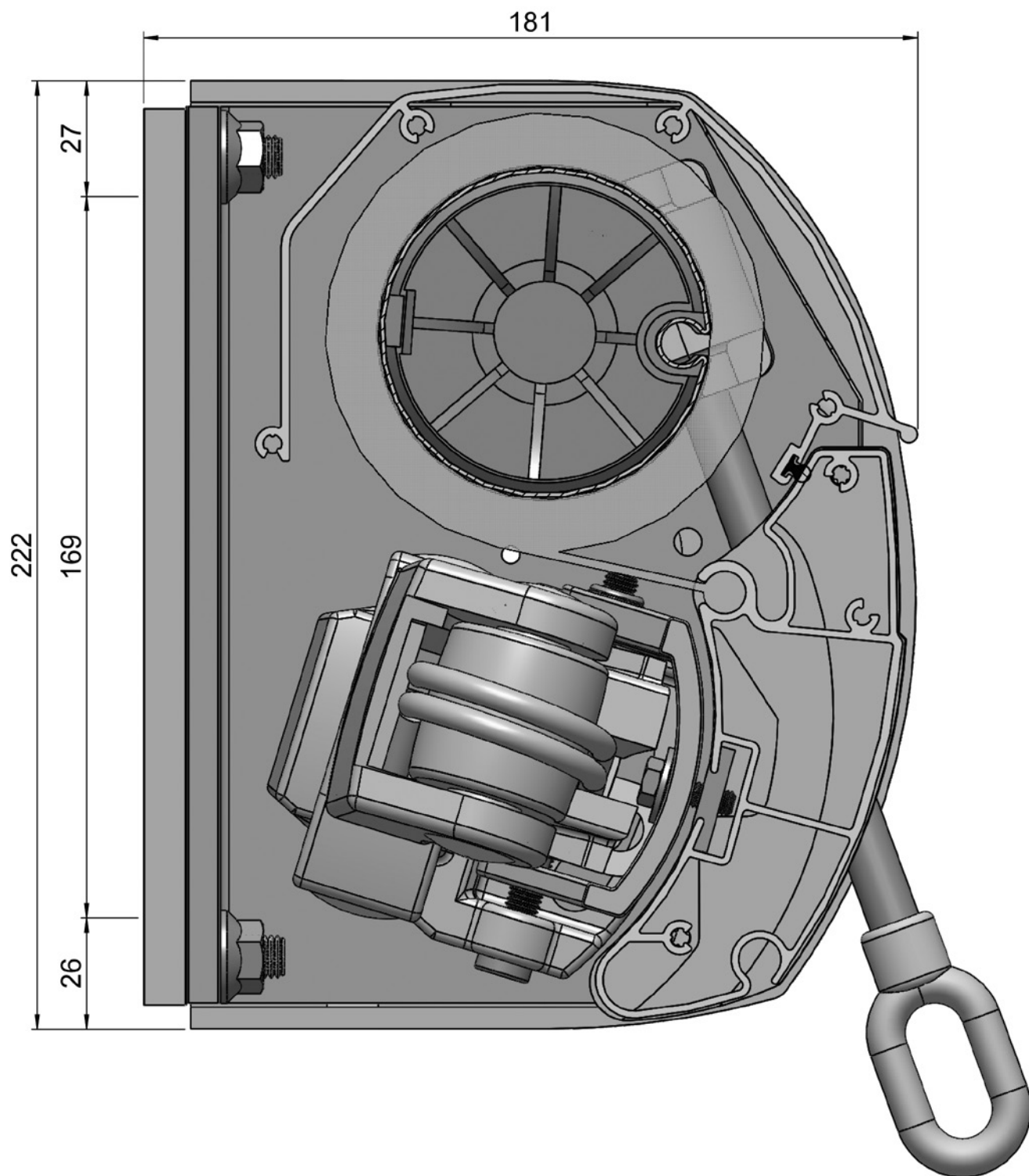

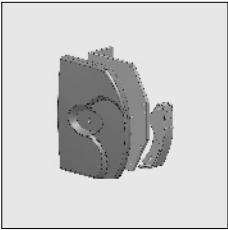



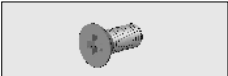

Furore® semi cassette

3

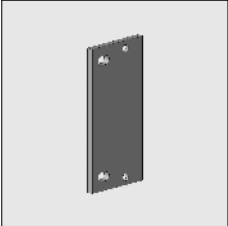
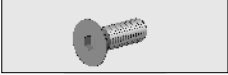

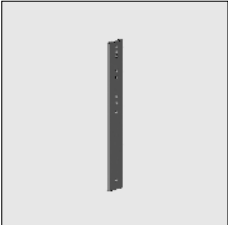
Part number	Description	Paint finish	Length in m ¹ Pack. unit
	4211 094-090 Top cover support kit Furore, consisting of: alu top cover supports, alu end caps and alu front profile-end caps	Mill finish	
	4211 094-901 Top cover support kit Furore, consisting of: alu top cover supports, alu end caps and alu front profile-end caps	RAL 9001 cream	
Note.: on request separate available.			
	4000 270-000 Stainless steel cross screw, cylinder screw M6 x 12 mm (For fixing the alu end cap to the top cover support)		100
	4000 162-000 Plate screw countersunk Philips head M5 x 12 mm (For fixing the nylon end cap to the top cover support).		100
	4210 186-080 Transparent decal, fits in the recess of the end cover.		2
	4210 140-000 Stainless steel Plate screw countersunk Philips head 4.2 x 22 mm (For fixing the end cap to the front profile).		100
	4211 120-090 Alu fastening plate for top cover support Furore	Mill finish	
	4211 120-901 Idem	RAL 9001 cream	
For fixing the top cover supports to the mounting plate			
	4210 481-000 Socket-head bolt with countersunk head M10 x 30 mm		50
	4211 150-000 Stainless steel flange nut M10		50
The top cover supports can be combined with:			
	4210 181-901 Steel wall strip 565 x 70 x 15 mm	RAL 9001 cream	
	4210 183-068 Fixing kit for wall strip 4210 181- . . .		

= Article will be sold out. Special orders remain possible.

Furore® semi cassette

3

Part number	Description	Paint finish	Length in m ¹ Pack. unit
-------------	-------------	--------------	--

For fixing the folding arm to the top cover support:

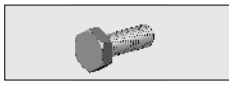

4211 160-000	Stainless steel hexagon bolt M10 x 30 mm		100
--------------	--	--	-----



4211 161-000	Stainless steel hexagon bolt M 10 x 40 mm		100
--------------	---	--	-----



4210 482-000	Stainless steel washer M10		50
--------------	----------------------------	--	----



4210 053-000	Stainless steel nut M10 (for hexagon bolt M 10 x 40 mm)		50
--------------	---	--	----

For operation through a gearbox the top cover support can be provided with a filling piece:

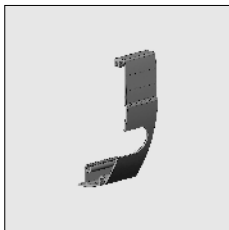

4211 128-901	Alu front profile-filling piece Furore, universal	RAL 9001 cream	
--------------	---	----------------	--



4210 141-000	Stainless steel cross screw, cylinder screw 4.2 x 22 mm (For fixing the filling piece to the top cover support).		100
--------------	---	--	-----

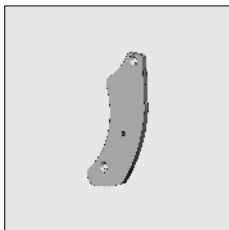

4211 122-000	Alu end cap for filling piece Furore	Mill finish	
--------------	--------------------------------------	-------------	--

4211 122-901	Idem	RAL 9001 cream	
--------------	------	----------------	--



4210 140-000	Plate screw countersunk Philips head 4.2 x 22 mm (For fixing the end cap to the filling piece).		100
--------------	--	--	-----

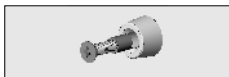



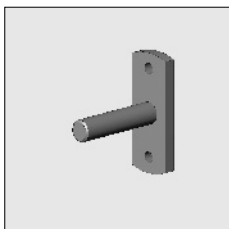

4211 124-080	Nylon guiding roll for Furore for guiding the front profile. To be attached to the top cover support and/or the end cap of the front profile- filling piece.		10
--------------	---	--	----

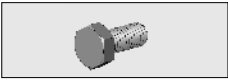

4210 498-080	Bearing pin 12 mm with wall bracket	Zinc-plated	10
--------------	-------------------------------------	-------------	----

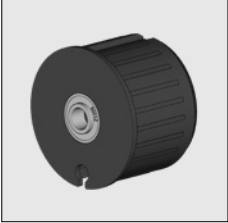
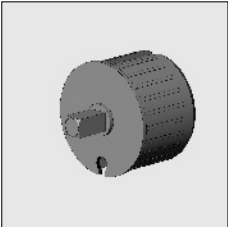
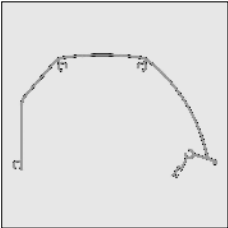
= Article will be sold out. Special orders remain possible.

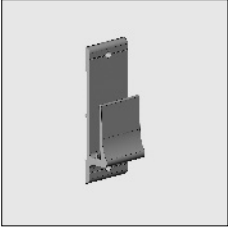
Part number	Description	Paint finish	Length in m ¹ Pack. unit
For fixing the bearing pin to the top cover support:			
	4410 272-000 Stainless steel hexagon bolt M6 x 14 mm		100
	4410 402-000 Stainless steel washer M6		100
	4470 080-068 Nylon bearing roller bung 78 incl. bearing with increased inner ring	Grey	10
	4470 088-000 Nylon mono plug 78, with square spindle 13 x 25 mm, flange 3 mm	Grey	
	4000 330-000 Alu mono plug 78, with square spindle 13 x 30 mm, flange 3 mm		
	6295 406-000 Alu top cover Furore	Mill finish	5.0
	6295 410-000 Idem	Mill finish	6.0
	6295 400-901 Alu top cover Furore	RAL 9001 cream	3.5
	6295 402-901 Idem	RAL 9001 cream	4.0
	6295 404-901 Idem	RAL 9001 cream	4.5
	6295 406-901 Idem	RAL 9001 cream	5.0
	6295 408-901 Idem	RAL 9001 cream	5.5
	6295 410-901 Idem	RAL 9001 cream	6.0
	4211 130-080 Nylon sealing for top cover	Black	50
	4211 132-080 Idem	White	50
	4210 141-000 Stainless steel cross screw 4.2 x 22 mm (For fixing the top cover support to the top cover).		100
	4210 060-901 Alu extruded bracket for top cover	RAL 9001 cream	

= Article will be sold out. Special orders remain possible.

Furore® semi cassette

Part number	Description	Paint finish	Length in m ¹ Pack. unit
-------------	-------------	--------------	--

The below mentioned flange can be used as a filling for the bracket for top cover:



4211 150-000	Stainless steel flange nut M10		50
--------------	--------------------------------	--	----

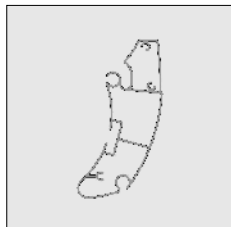

6295 456-000	Alu front profile Furore	Mill finish	5.0
6295 460-000	Idem	Mill finish	6.0
6295 450-901	Alu front profile Furore	RAL 9001 cream	3.5
6295 452-901	Idem	RAL 9001 cream	4.0
6295 454-901	Idem	RAL 9001 cream	4.5
6295 456-901	Idem	RAL 9001 cream	5.0
6295 458-901	Idem	RAL 9001 cream	5.5
6295 460-901	Idem	RAL 9001 cream	6.0

Further requirements:

- Rollers refer to chapter 1
- Multipurpose folding arms and accessories refer to chapter 2